

Installation of receiving devices should be carried out by a qualified electrician. Any device with the signs of damage and/or missing parts should not be installed and should be returned to the seller.

Before attempting installation, ensure all associated circuits and cables have been isolated at the source. Please refer to 'installation guidance notes' supplied before commencing with the installation.

Devices are designed to be mounted internally only.

1 RFSA-62B - 8A x 2 Channel Switching Receiver



The 16A 'Live In' powers the unit and supplies the two outputs. Two switched live outputs which can be controlled independently or together.

Press the 'PROG' button for 1 second to change between Output 1 (Green LED) and Output 2 (Red LED).

Receivers can be mounted directly behind individual appliances, control circuits locally or within the consumer unit. We recommend the receiver is installed inside a non-metallic enclosure.

The programme button is set back in to the housing. A thin blunt implement e.g. stylus can be used to press and hold the programming button.

We recommend noting the hexadecimal codes printed on each receiver channel and the appliances each one is controlling for potential future use.

Each channel can be controlled by up to 12 transmitting devices.

CS2 Memory: The product marked CS2 enables the receiver to remember the status (if engaged) in the event of a power cut. Once engaged and the current status has been running for longer than 15 seconds the current status will be stored. See 'Step 4' overleaf.



















2 Signal Range

The RFSA-62B has a signal range in free air of up to 100 metres.

Once the signal penetrates building materials etc. the signal range will be reduced. See the installation guidance notes supplied with this device.

3 Load Type

! Warning Inductive and resistive loads **MUST NOT** be connected together through one channel

Type of load	 cos φ ≥ 0.95 AC1	 AC2	 AC3	 AC5a uncompensated	 AC5a compensated	 AC5b	 AC6a	 AC7b	 AC12
Contact material AgSnO ₂ contact 8A	250V / 8A	250V / 5A	250V / 4A	x	x	250W	250V / 4A	250V / 1A	250V / 1A
Type of load	 AC13	 AC14	 AC15	 DC1	 DC3	 DC5	 DC12	 DC13	 DC14
Contact material AgSnO ₂ contact 8A	x	250V / 4A	250V / 3A	30V / 8A	24V / 3A	30V / 2A	30V / 8A	30V / 2A	x

4 Wiring

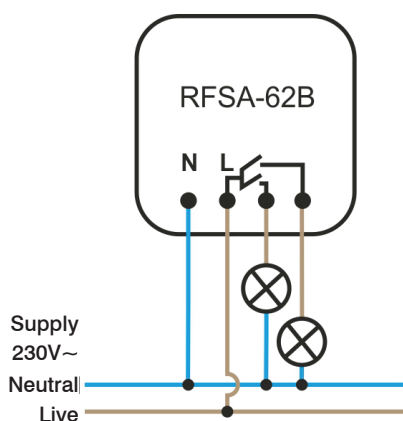

The 16A 'Live In' powers the unit and supplies the two outputs. Two switched live outputs which can be controlled independently or together.

Press the 'PROG' button for 1 second to change between Output 1 (Green LED) and Output 2 (Red LED).

5 Functions (Switching Receivers)

Function 1	Press Button	Press for ON, release for OFF
Function 2	'ON' Button	Press for ON
Function 3	'OFF' Button	Press for OFF
Function 4	ON/OFF Button	Press for ON, press again for OFF
Function 5	'OFF' Delay	Press for ON, device will turn off after predetermined time period as set in STEP 3 of programming (2 seconds to 60 mins)
Function 6	'ON' Delay	Press to start timer. 'ON' delay will be as predetermined in STEP 3 of programming (2 seconds to 60mins)

Functions 5 & 6 (timed elements) are programmed in real time. If you require 30 minutes you have to wait for the 30 minutes to complete the pairing. To help save time and remove potential frustration on 5+ minute timed elements, we always recommend conducting a few shorter timed elements (e.g. 10 seconds) to ensure both the correct function and the correct timed element are programmed.

6 Programming The Receiver To Button Transmitters

When installing with the RF Pilot or RF Touch, use the dedicated product manuals for programming. Press the 'PROG' button for 1 second to change between Output 1 (Green LED) and Output 2 (Red LED). Each channel must be programmed independently. Ensure both green and red LED's are not flashing simultaneously.

STEP 1 - Programming Mode

Press & hold the 'programming' button on the receiver for 3 seconds (the status LED will flash with a 1 second interval).

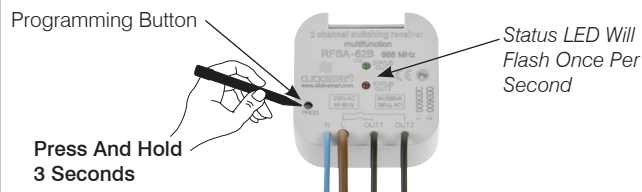

The programme button is recessed in to the body, this is standard. A small implement e.g. stylus can be used to press and hold the button.

STEP 3 - Only Required For Functions 5 & 6 (Time Elements) For All Other Functions Go To STEP 4

To set the time element, whilst still in programming mode, press & hold the 'programming' button again for '5 seconds' (the status LED will flash twice a second). **THE TIMER HAS NOW STARTED.**

When the required time period has elapsed, to stop the timer press the assigned transmitter button (IN STEP 2) once.

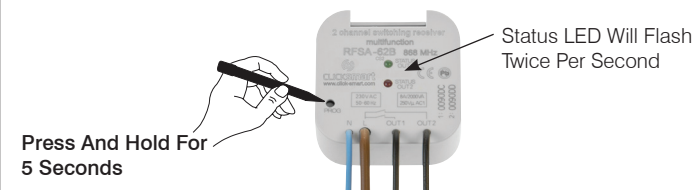

To Remove A Single Transmitter Button From The Receiver

STAGE 1

Press And Hold For 6 Seconds

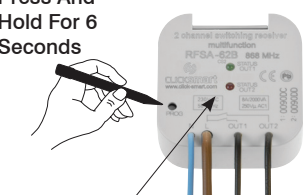

STAGE 2

Transmitter Button

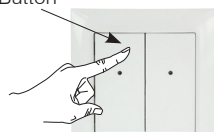

Press The Transmitter Button Once To Remove. The Receiver LED Status Should Be OFF

STEP 2 - Select Function

To assign the required transmitter button & function, press the required button the number of times to match the function number (e.g function 2, press the button 2 times).

Press the transmitter button at one second intervals - See table of functions above.

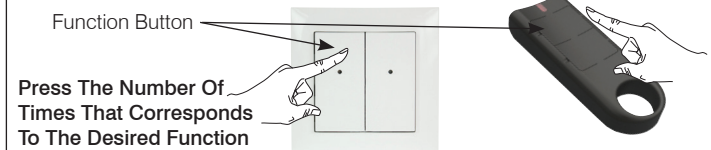

Each time the transmitter button is pressed the LED on the receiver will also flash to confirm the signal has been received.

STEP 4 - Save & Exit

To exit programming mode press the 'programming' button for less than 1 second.



CS2 - Memory Status

Single LED flash on exit - Memory status not engaged

Double LED flash on exit - Memory status is engaged

To toggle between status's enter and exit programming mode.

To Remove All Paired Buttons

Press And Hold The 'Programming' Button For Longer Than 9 Seconds.

The LED status will change over the 9 seconds.

After 2 seconds the LED will flash once per second. After 5 seconds the LED will flash three times per second and after 8 seconds will go back to flashing once per second, release the programming button.

Press the programme button for less than 1 second to exit programming mode and remove all paired buttons.

